

Charter • Charter TR SE

BUMPER PULL



The Charter Bumper Pull is a 2 horse straight load trailer that is also available in a Charter TR SE which has a large front tack room. Both trailers come standard with two large sliding windows in the horse area, a divider between the stalls, a side access door per stall and are 7' 6" tall. The Charter TR SE has two saddle racks in the tack room along with two large windows in the nose, a window in the tack door, and it also has windows in the rear tail curtains. Both trailers are built with the same quality and standards that are expected from a Sundowner.

STANDARD FEATURES

- 2 5/16" Bumper pull hitch
- 2 Horse
- Straight load
- 6'9" Wide
- 7'6" Tall
- 38" Wide stalls
- All aluminum construction
- All aluminum floor
- Prepainted aluminum exterior
- Rubber torsion axles
- 4 Wheel electric brakes with safety breakaway
- Spare tire (TR SE only)
- Full length running boards (TR SE only)
- LED clearance & tail lights
- Top wind jack
- Graphics package

HORSE AREA

- Padded airflow head and shoulder divider with butt bar and breast bar per stall
- Floor mats in horse area
- Large sliding window per stall
- Side access door with sliding window per stall
- SunCoated™ side walls (double wall construction)
- Spring loaded rear ramp with wrap around tail curtains
- Windows in curtain on the TR SE only
- Pop up vent per horse stall
- Dome light in horse area
- 1 Outside and 2 inside tie rings per stall



Charter TR SE Bumper Pull with Tack Room

FRONT TACK STORAGE

(Charter TR SE only)

- Locking tack door with window
- Rubber floor mats
- Dome light
- 6 Tack hooks
- Blanket bar
- Brush tray
- 2 sliding windows in the nose
- Sliding window in tack wall
- 2 Saddle racks

POPULAR OPTIONS

- Skin colors: white, black, silver, charcoal, champagne
- Additional interior dome light(s)
- Spare tire (Charter only)
- Load lights
- Tread plate gravel guard

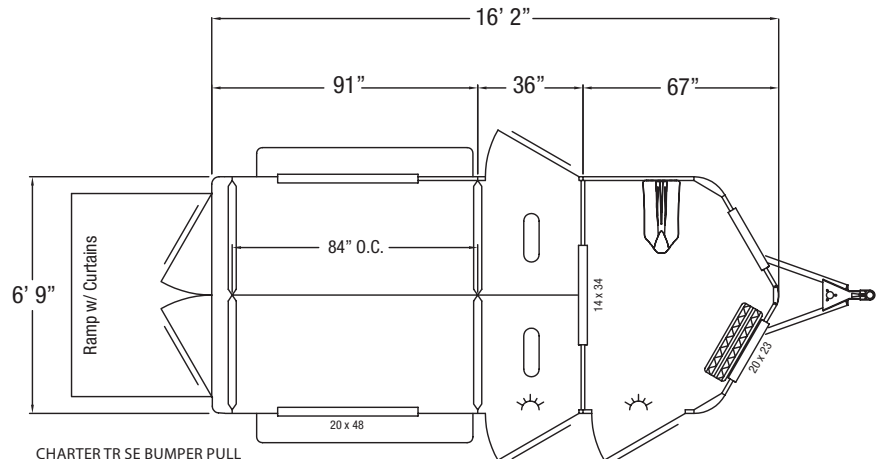
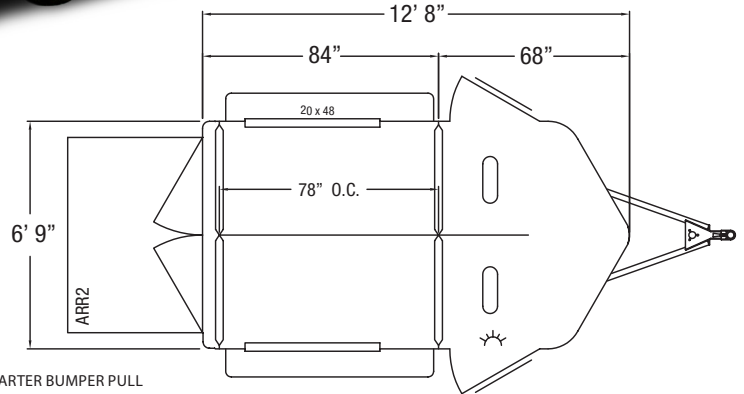

Charter SE Bumper Pull with Tack Room

EVANS

TRAILER & RV